

Step 1

Place support tube on bottom of desk. Place two brackets (WFG# 500800F) on stiffener tube and align to pilot holes. Attach using #10 x 3/4" wood screws provided (FIG-1).

Note:

On the 84" wide desks, the 3 brackets are replaced by one bracket (WFG# 490155F) that spans the length of the support tube.

Step 2

Attach legs next. Align holes in leg brackets to the threaded inserts in desk. Attach legs to desk with 1/4-20 x 3/8" machine screws provided (FIG-2).

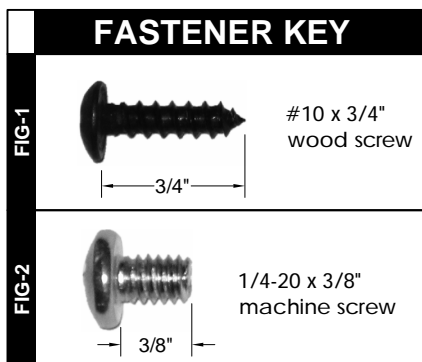
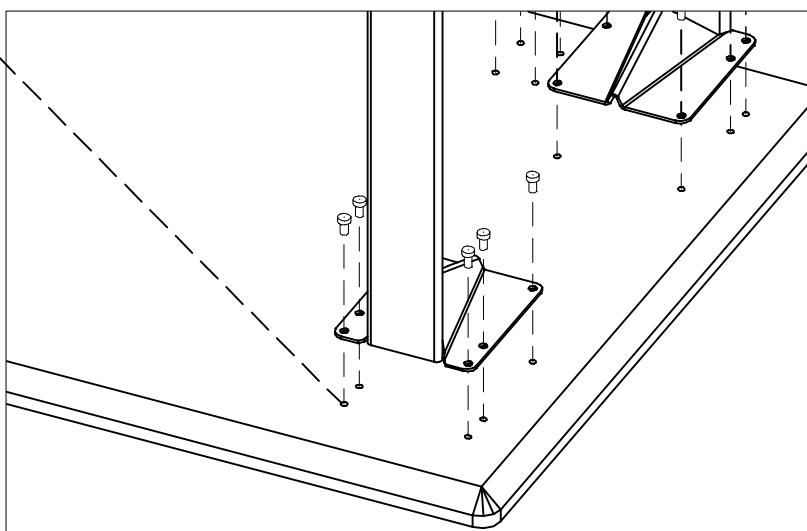



Step 1

Align the two halves of the Verve worksurface.

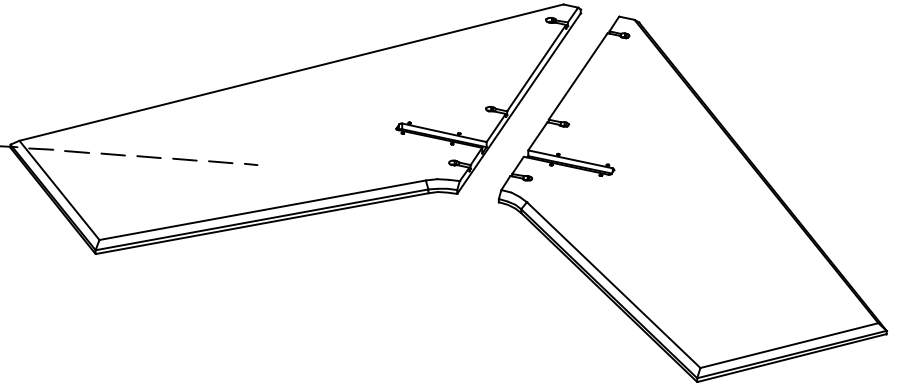

Step 2

Slip the joint connectors into the pockets and use the thin rod provided to tighten the ball shaped nuts. Make sure the top of the two halves of the worksurface are tight and flush.

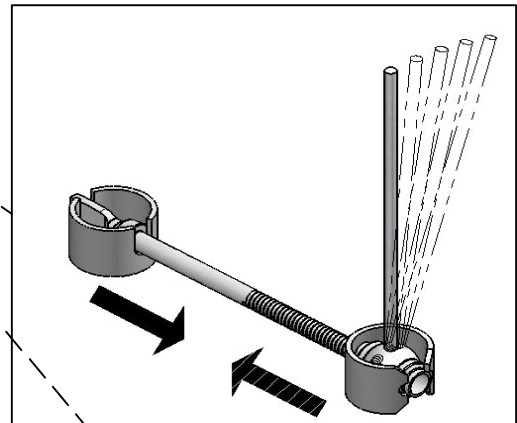

Step 3

Drop steel hat channel in place and secure with 1/4-20 x 3/8" machine screws (FIG-2).

Finish assembly by attaching support tubes and legs as shown on page 1.

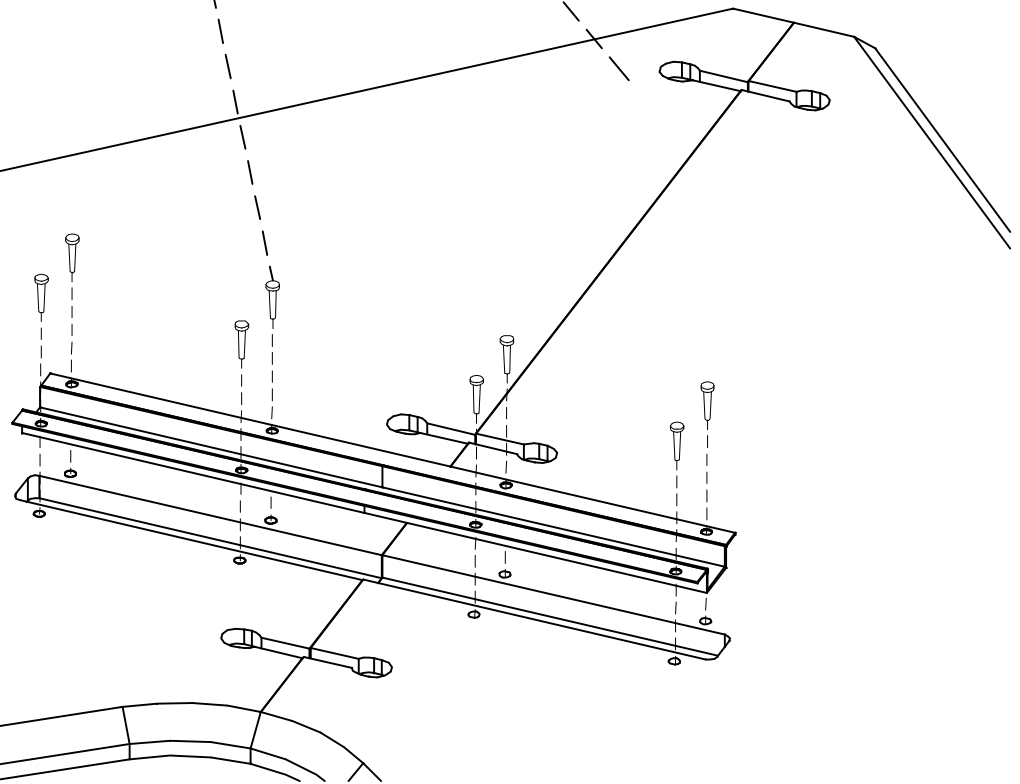

FASTENER KEY

FIG-2



1/4-20 x 3/8"
machine screw

3/8"