

Step 1

Center stiffener tube in pocket. Position 2 clamping brackets (WFG# 490154F) on the ends of the tube and the 3rd bracket in the center. align brackets to pilot holes and secure with 3/4" wood screws provided.

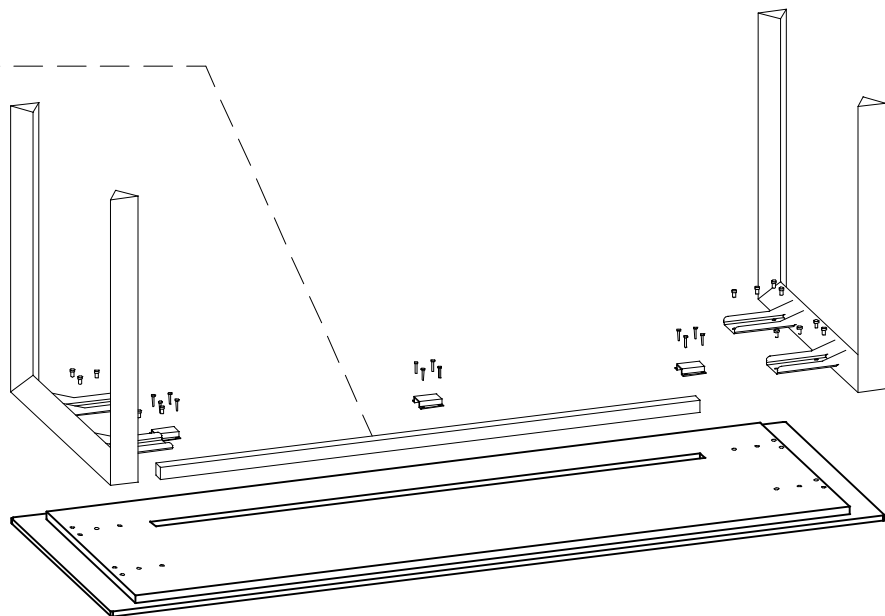

Step 2

Attach legs next. Align holes in leg brackets to the threaded inserts in worksurface. Attach legs to top with 1/4-20 machine screws provided.

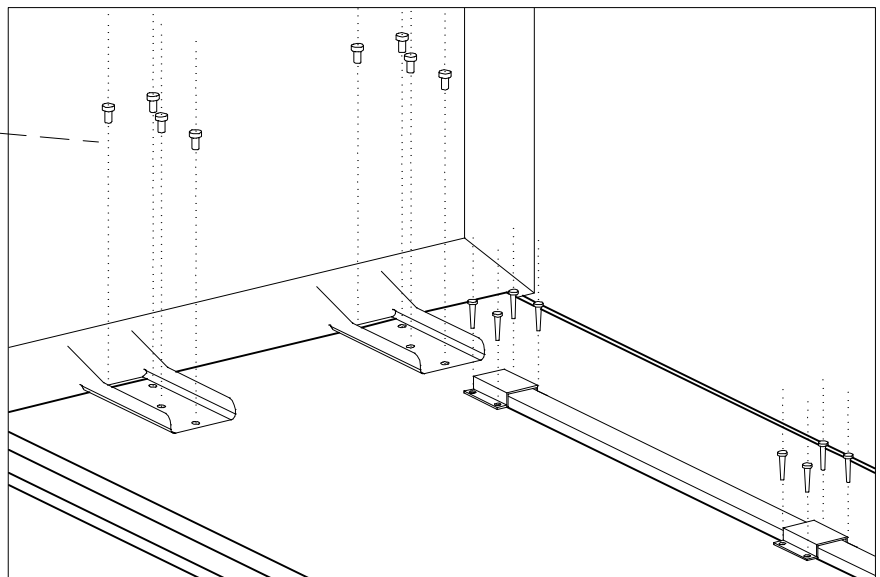



Step 3

Align the two halves of the verve table top.

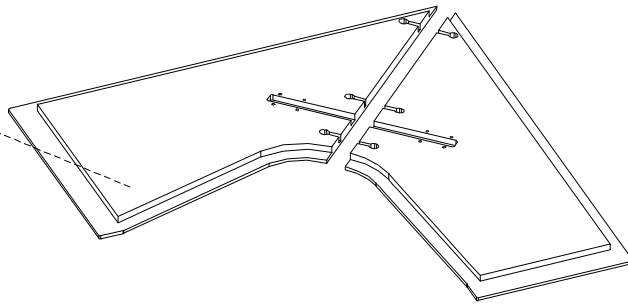

Step 3

Slip the 3 joint connectors into the pockets and use the thin rod provided to tighten the ball shaped nuts. Make sure the top of the two halves of the worksurface are tight and flush.

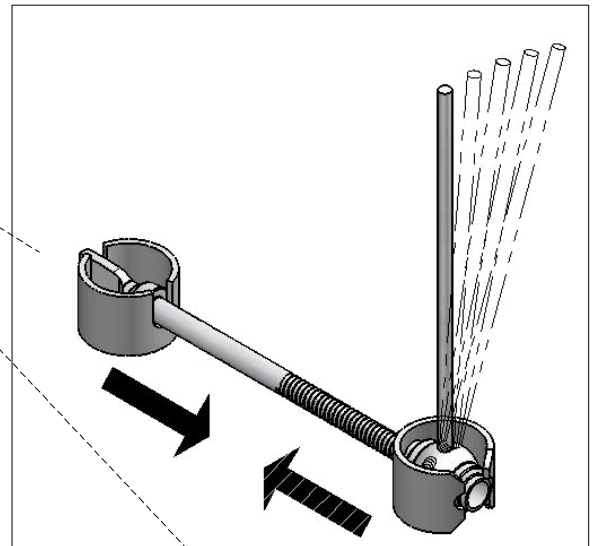

Step 3

Drop steel hat channel in place and secure with 8 each 1/4"-20 by 3/8" long pan head screws.

Complete assembly by now attaching stiffener tubes and legs as shown on page one.

