

# ASSEMBLY

In-Surface Dual-Hinge Power

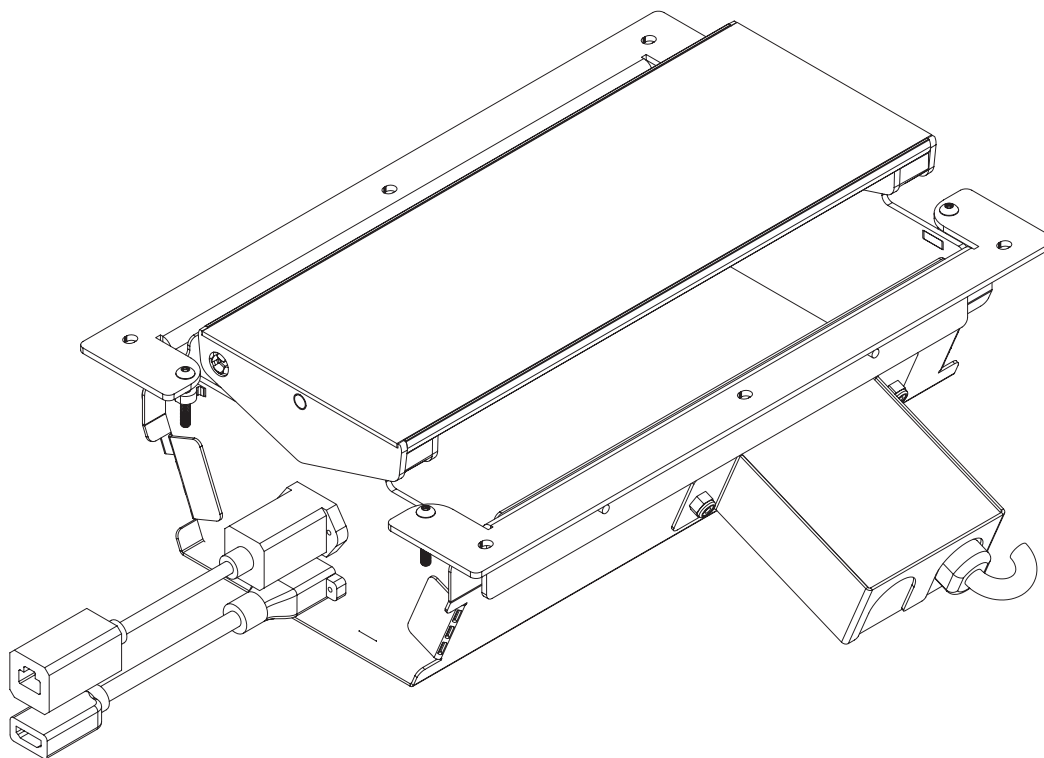

View Digitally

# Components

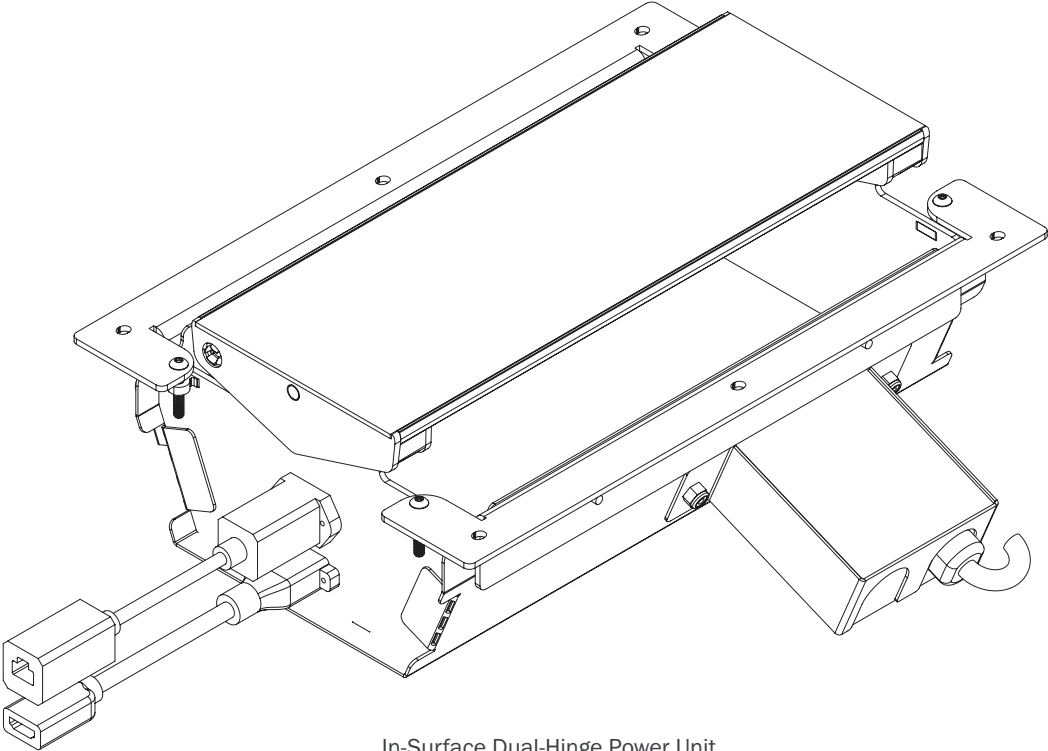

In-Surface Dual-Hinge Power Unit

# Hardware

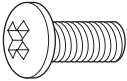

#10 x 1/2"  
Philips Screw  
(122815)

# 1. Attach the Power Unit to the Top

If the surface is a wood grain laminate, orient the power unit with the lids matching the direction of the grain on the surface. The (2) L-brackets should be loosely attached to the unit through slots in the side of the power pan.

Secure the power unit to the underside of the worksurface through the mounting holes in the L-brackets. If applicable, connect an HDMI or CAT6 data cable to the female/female adapters provided (1a).

With the (4) inner L-bracket screws loose, adjust the (4) screws in the outer corners of the cutout until the flip lid is flush with the worksurface (1b).

Tighten the (4) side screws once levelness is achieved (1c).

